

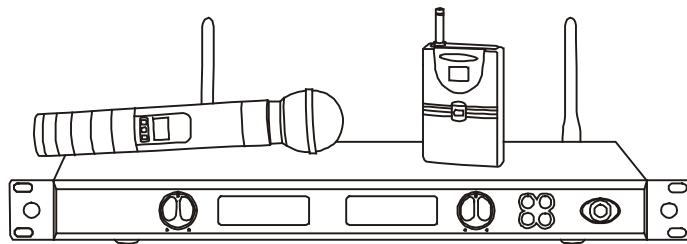

MULTI-CHANNELS WIRELESS MICROPHONE SYSTEM

# OPERATION MANUAL



- 1 Safety and Environment.....1**
- 2 System Composition .....1**
- 3 Operations of microphones .....1**
  - 3.1 Handhold microphone T01.....1
  - 3.2 Handhold microphone T04.....2
  - 3.3 Handhold microphone T08.....3
  - 3.4 Body-pack microphone T10 .....4
  - 3.5 Handhold microphone T11.....4
  - 3.6 Body-pack microphone T12 .....5
  - 3.7 Handhold microphone T13.....6
  - 3.8 Handhold microphone T14.....7
- 4 Operations of receivers .....8**
  - 4.1 True diversity receiver 8010 .....8
  - 4.2 Rack mounting a single 8010 receiver .....9
  - 4.3 Mounting two 8010 receiver side by side .....9
  - 4.4 Receiver 8220 .....10
  - 4.5 Receiver 8221 .....11
  - 4.6 Diversity receiver 8222 .....12
  - 4.7 Receiver 8223 .....14
  - 4.8 True diversity receiver 8240.....15
  - 4.9 True diversity receiver 8242.....17
- 5 Specifications .....18**
  - 5.1 Specifications of microphones .....18
  - 5.2 specifications of receivers .....18

There are several model products including in this manual. Please take a few minutes to read the content about your system model before operating the equipment.

Microphone: T01 T04 T08 T10 T11 T12 T13 T14      Receiver: 8010 8220 8221 8222 8223 8240 8242

## MAIN FEATURE:

- UHF 800MHz international universal band
- Twice mixer superheterodune circuit design for high receive sensitivity
- Excellent SAW filter for RF and IF circuit for excellent anti-jamming performance
- Auto-mute and anti-skip circuit eliminates the skipping caused by the boot-strap and the other noise
- Professional audio output: balanced XLR and unbalanced 1/4" jack
- Collocating all-pervading AA size batteries for transmitter
- Dual DC-DC step up circuit for transmitter for steady RF output power
- Manufactured by Surface-Mounting Technology (SMT)

## 1 Safety and Environment

- 1.1 To reduce the risk of electrical shock, do not open the unit. There are no user replaceable parts inside.
- 1.2 Please Check if the AC voltage stated matches the receivers before connecting the power cable in Receiver. Otherwise may cause irreparable damage to the unit. If not use for long time, please take out batteries form transmitter, and take out the plug form AC socket.
- 1.3 Do not place the equipment near heat sources such as radiator, heating ducts, amplifiers and etc. Do not expose this to direct sunlight, excessive dust, moisture, rain and the place near mechanical vibrations or shock. For perfect effect, keep away from electric power lines, big metal object, computer, radar station and etc.

## 2 System Composition

This series wireless microphone system composes of handhold type (or body-pack type) microphone, receiver, power adapter (or internal power convertor), audio cable, batteries, assistant fixing rack, channel adjustment screwdriver and etc. There are several model products including in this manual, please read the content about your system model before connect and use your equipment.

## 3 Operations of microphones

### 3.1 Handhold microphone T01

#### 3.1.1 Install batteries

Handhold microphone T01 was shown in Fig.1. Take out the microphone from packing box, open the battery cover, insert two AA size alkaline batteries in right polarity marks, and close the battery cover.

#### 3.1.2 Turn on or turn off the microphone

Push the power switch to "ON", then the power indicator (BATT) will flash once and off, means the batteries are effective and the microphone can work. Please replace the batteries when the power indicator light on without off (shortage of the batteries), no indicator ever light on or flash (out of power); and the indicator shows in the course of the microphone working (almost out of power).

#### 3.1.3 Change channel

If necessary, screw the channel selector with the supplied screwdriver to select another channel. The system can work normally when the microphone and the receiver in the same group and same channel.

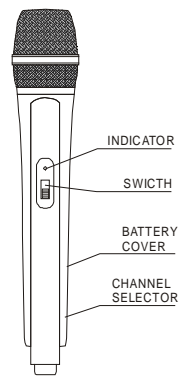

Fig.1 Handhold microphone T01

The channel selector of microphone T01 under the battery cover, see Fig.2. The channel in Fig.2 are 0 channel. The group mark also found in the bottom of the microphone, see Fig.3.

### 3.1.4 About Band, Group and Channel

The operating frequency of handheld microphone T01 lie on band, group and channel. The band and group decided by manufactory, and user can't change, user can select one channel from sixteen channels. Only belong to one same band, and one same group, and be selected to a same channel, the microphone could cooperate with the receiver.

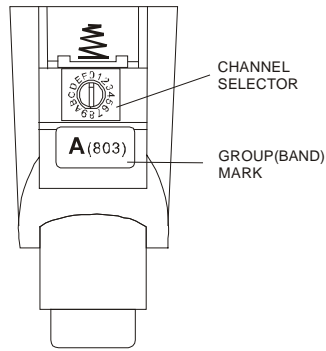

Fig.2 Channel selector and mark

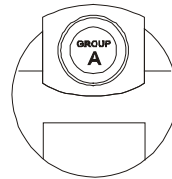

Fig.3 Group mark of T01

## 3.2 Handhold microphone T04

### 3.2.1 Install batteries

Handhold microphone T04 was shown in Fig.1. Take out the microphone from packing box, screw open the battery cover, insert one 6F22 type battery in right polarity marks, and screw close the battery cover.

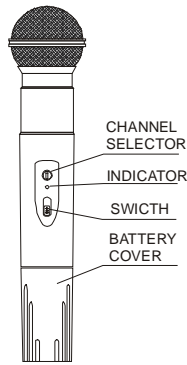

Fig.4 Handhold microphone T04

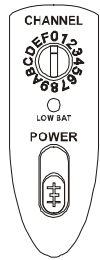

Fig.5 Panel of T04

### 3.2.2 Turn on or turn off the microphone

Push the power switch to "ON", then the power indicator (LOW BAT) will flash once and off, means the batteries are effective and the microphone can work. Please replace the battery when the power indicator light on without off (shortage of the batteries), no indicator ever light on or flash (out of power); and the indicator shows in the course of the microphone working (almost out of power).

### 3.2.3 Change channel

If necessary, screw the channel selector with the supplied screwdriver to select another channel. The channel selector of handhold microphone T04 are on the panel, see Fig.5. The channel in Fig.5 are 0 channel. The system can work normally when the microphone and the receiver in the same group and same channel.

### 3.2.4 About Band, Group and Channel

The operating frequency of handheld microphone T04 lie on band, group and channel. The band and group decided by manufactory, and user can't change, user can select one channel from sixteen channels. Only belong to one same band, and one same group, and be selected to a same channel, the microphone could cooperate with the receiver.

## 3.3 Handhold microphone T08

### 3.3.1 Install batteries

Handhold microphone T08 was shown in Fig.6. Take out the microphone from packing box, and take out the antennae of the microphone, screw the antenna into the nut in the bottom of the microphone, then screw open the battery cover, insert two AA size alkaline batteries in right polarity marks, and screw close the battery cover.

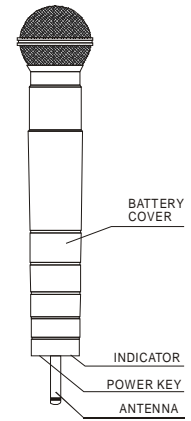

Fig.6 Handhold microphone T08

### 3.3.2 Turn on or turn off the microphone

The bottom panel of the handhold microphone T08 was shown in Fig.7. Press the power button (ON/OFF) to turn on or turn off the microphone. In the time of turn on the microphone, the power inductor will light on. The color of the inductor will be orange, and soon translate to green. This means the batteries are effective and the microphone can work. If no indicator ever light on or the inductor translated to orange, please replace the batteries.

### 3.3.3 Change channel

If necessary, screw open the battery cover, screw the channel selector locate the reverse of the batteries room with the supplied screwdriver to select another channel. The channel selector of handhold microphone T08 was shown in Fig.8. The channel number in Fig.8 are 0 channel. The system can work normally when the microphone and the receiver in the same group and same channel.

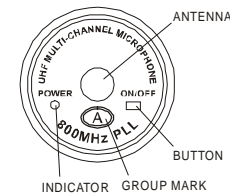

Fig.7 Bottom panel of T08

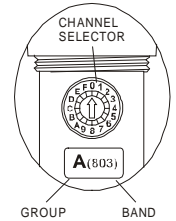

Fig.8 Channel selector of T08

### 3.3.4 About Band, Group and Channel

The operating frequency of handheld microphone T08 lie on band, group and channel. The band and group decided by manufactory, and user can't change, user can select one channel from sixteen channels. Only belong to one same band, and one same group, and be selected to a same channel, the microphone could cooperate with the receiver.

### 3.4 Body-pack microphone T10

#### 3.4.1 Install batteries

The body-pack microphone T10 was shown in Fig.9. Take out the microphone from packing box, open the battery cover, insert two AA size batteries in right polarity marks, and close the battery cover.

#### 3.4.2 Turn on or turn off the microphone

Push the power switch to "ON", the indicator will light on, the color of the inductor will be orange, and soon translate to green. This means the batteries are effective and the microphone can work. If no indicator ever light on or the inductor translated to orange, please replace the batteries.

#### 3.4.3 Change Gain

If necessary, set the Gain knob shown in Fig.10 with the supplied screwdriver to get proper volume without feedback.

#### 3.4.4 Change Channel

If necessary, screw the channel selector with the supplied screwdriver to select another channel. The channel selector of body-pack microphone T10 are in the battery room, see Fig.10. The channel in Fig.10 are 0 channel. The system can work normally when the microphone and the receiver in the same group and same channel.

#### 3.4.5 About Band, Group and Channel

The operating frequency of handhold microphone T10 lie on band, group and channel. The band and group decided by manufactory, and user can't change, see Fig.10. User can select one channel from sixteen channels. Only belong to one same band, and one same group, and be selected to a same channel, the microphone could cooperate with the receiver.

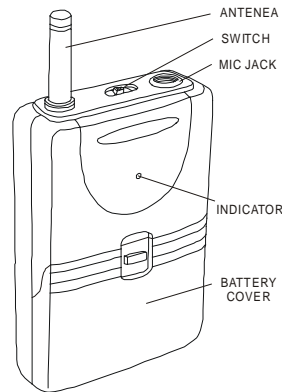

Fig.9 Bodypack microphone T10

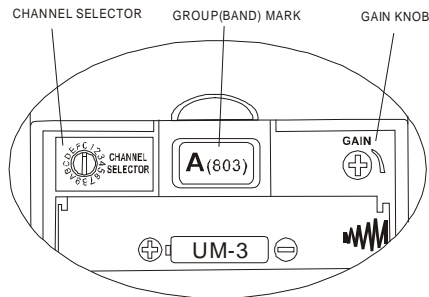

Fig.10 Channel selector of T10

### 3.5 Handhold microphone T11

#### 3.5.1 Install batteries

The handhold microphone T11 was shown in Fig.11. Take out the microphone from packing box, and take out the antennae of the microphone, screw the antenna into the nut in the bottom of the microphone, screw open the battery cover, insert two AA size alkaline batteries in right polarity marks, and screw close

the battery cover.

#### 3.5.2 Turn on or turn off the microphone

Press the power button (POWER) to turn on or turn off the microphone. In the time of turn on the microphone, the operation frequency or channel number and the power level will displays on the LCD screen, see Fig.12. In the time of turn off the microphone, the LCD screen will display "OFF" and then gone out.

#### 3.5.3 Change channel

Screw the key anticlockwise and keep for a moment, the "MHz" in the LCD screen will flash, then release the key, and screw the key clockwise or anticlockwise again to change the operation frequency. Then press the power button (POWER) once to finish change, so the "MHz" will stop flash.

#### 3.5.4 Change the display content

The LCD screen may display operation frequency or channel number. To change the display content, screw the key clockwise and keep for a moment, the "MHz" in the LCD screen will flash, then release the key, and screw the key anticlockwise, the display content will alternately between the frequency and the channel number. Press the power button (POWER) once to make sure and quit, and the "MHz" in the LCD screen will stop flash.

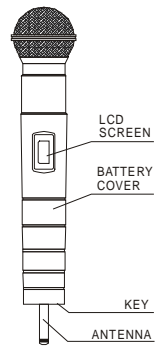

Fig.11 Handhold microphone T11

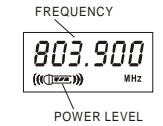

Fig.12 Screen of T11

### 3.6 Body-pack microphone T12

#### 3.6.1 Install batteries

Body-pack microphone T12 was shown in Fig.13. Take out the microphone from packing box, open the battery cover, insert two AA size alkaline batteries in right polarity marks, and close the battery cover.

#### 3.6.2 Turn on or turn off the microphone

Press the power button to turn on or turn off the microphone. In the time of turn on the microphone, the operation frequency or channel number and the power level will displays on the LCD screen, see Fig.14. In the time of turn off the microphone, the LCD screen will display "OFF" and then gone out.

#### 3.6.3 Change Gain

If necessary, set the Gain knob shown in Fig.15 with the supplied screwdriver to get proper volume without feedback. The strong sound feedback may damage your audio equipment.

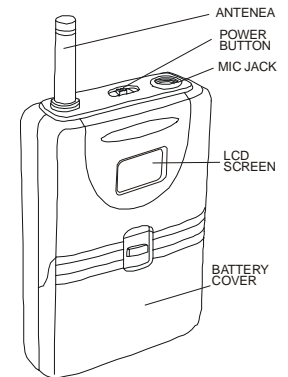

Fig.13 Body-pack microphone T13

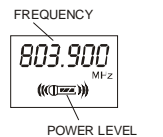

Fig.14 Screen of T12

### 3.6.4 Change Channel

Press the UP button and keep for a moment, the "MHz" in the LCD screen will flash, then release the UP button, and press the UP button or the DOWN button again to change the operation frequency. Then press the power button (POWER) once to finish change, so the "MHz" will stop flash.

### 3.6.5 Change the display content

The LCD screen may display operation frequency or channel number. To change the display content, press the DOWN button and keep for a moment, the "MHz" in the LCD screen will flash, then release the DOWN button, and press the UP button, the display content will alternately between the frequency and the channel number. Press the power button once to make sure and quit, and the "MHz" in the LCD screen will stop flash.

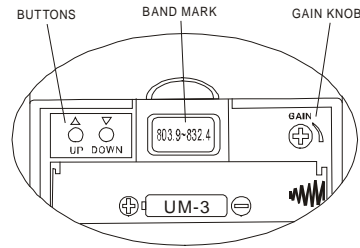

Fig.15 Battery room of T12

## 3.7 Handhold microphone T13

### 3.7.1 Install batteries

Handhold microphone T13 was shown in Fig.16. Take out the microphone from packing box, screw open the battery cover, insert two AA size alkaline batteries in right polarity marks, and screw close the battery cover.

### 3.7.2 Turn on or turn off the microphone

Push the power switch to "ON", then the power indicator (BATT LOW) will flash once and off, means the batteries are effective and the microphone can work. Please replace the batteries when the power indicator light on without off (shortage of the batteries), no indicator ever light on or flash (out of power); and the indicator shows in the course of the microphone working (almost out of power).

### 3.7.3 Change channel

If necessary, screw open the battery cover, screw the channel selector locate in the batteries room with the supplied screwdriver to select another channel. The channel selector of handhold microphone T13 was shown in Fig.17. The channel number in Fig.17 are 0 channel. The system can work normally when the microphone and the receiver in the same group and same channel.

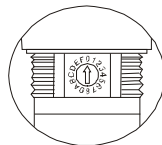

Fig.17 Channel selector of T13

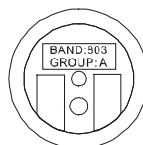

Fig.18 Bottom panel of T13

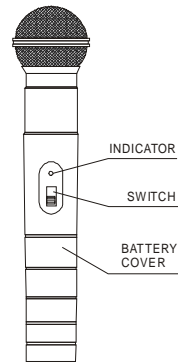

Fig.16 Handhold microphone T13

### 3.7.4 About Band, Group and Channel

The operating frequency of handhold microphone T13 lie on band, group and channel. The band and group decided by manufactory, marked on the bottom panel of the microphone, see Fig.18, and user can't change, user can select one channel from sixteen channels. Only belong to one same band, and one same group, and be selected to a same channel, the microphone could cooperate with the receiver.

## 3.8 Handhold microphone T14

### 3.8.1 Install batteries

Handhold microphone T14 was shown in Fig.19. Take out the microphone from packing box, screw open the battery cover, insert two AA size alkaline batteries in right polarity marks, and screw close the battery cover.

### 3.8.2 Turn on or turn off the microphone

Press the power button (●) to turn on or turn off the microphone. In the time of turn on the microphone, the operation frequency or channel number and the power level will displays on the LCD screen, see Fig.20. In the time of turn off the microphone, the LCD screen will display "OFF" and then gone out.

### 3.8.3 Change Channel

Press the UP button (▲) and keep for a moment, the "MHz" in the LCD screen will flash, then release the UP button (▲), and press the UP button (▲) or the DOWN button (▼) again to change the operation frequency. Then press the power button (●) once to finish change, so the "MHz" will stop flash.

### 3.8.4 Change the display content

The LCD screen may display operation frequency or channel number. To change the display content, press the DOWN button (▼) and keep for a moment, the "MHz" in the LCD screen will flash, then release the DOWN button (▼), and press the UP button (▲), the display content will alternately between the frequency and the channel number. Press the power button (●) once to make sure and quit, and the "MHz" in the LCD screen will stop flash.

### 3.8.5 Change the screen light mode

There are two light modes for microphone T14 with screen light: "ON" and "OFF". In the "ON" mode, the screen light keep lighting when the microphone was turn on; in the "OFF" mode, the screen light keep lighting only some button be pressed down. To change the screen light mode, press the DOWN button (▼) and keep for a moment, the "MHz" in the LCD screen will flash, then release the DOWN button (▼), press the DOWN button (▼) again, "LEd oN" or "LEdoFF" will shown, press the UP button (▲), the display content will change between the "LEd oN" and "LEdoFF". Press the power button (●) once to make sure and quit, and the "MHz" in the LCD screen will stop flash.

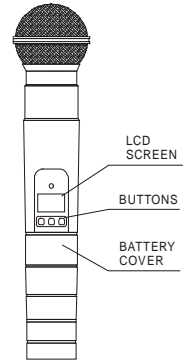

Fig.19 Handhold microphone T14

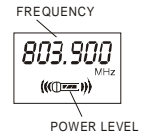

Fig.20 Screen of T14

## 4 Operations of receivers

### 4.1 True diversity receiver 8010

4.1.1 Receiver 8010 was shown in Fig.21. Take out the receiver from packing box and place the receiver near the performance area (stage). Point the antennas upward and slightly outward to form a “V”. Make sure, that the transmitter (microphone) will never get any closer to the receiver than 10 ft (3m), optimum separation is 16 ft (5m). There should always be a direct line of sight between the microphone and receiver. Place the receiver least 5 ft (1.5m) away from any big metal objects, walls, scaffolding, ceilings, etc.

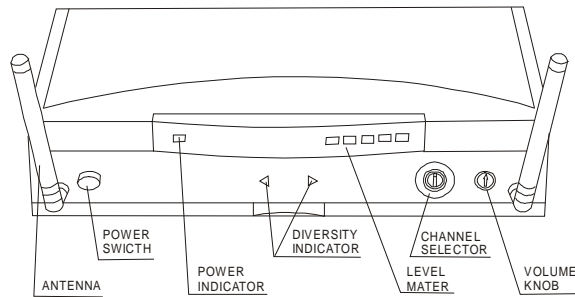

Fig.21 Receiver 8010

- 4.1.2 Make sure the GROUP and the CHANNEL of the receiver are same to the microphone. The GROUP mark and CHANNEL listing of receiver 8010 in the rear panel, you can get the operation frequency of system from it.
- 4.1.3 Connect AUDIO OUT in receiver and MIC INPUT in the amplifier with the supplied unbalanced audio cable. The Balanced socket specializes in connecting sound stage with the optional balanced audio cable. So it is necessary to push the Balanced Output Level Switch (Receiver) at “LINE” or “MIC” according to the usage. Do not use the Balanced and Unbalanced Sockets simultaneously! This may cause signal loss or increased noise.
- 4.1.4 Check if the AC voltage stated on the supplied DC adapter matches the receivers before connecting the power cable in Receiver. Otherwise may cause irreparable damage to the unit.
- 4.1.5 Adjust the volume of the receiver and amplifier to “MIN” and push the receiver ON, then the two Diversity indicators will flash alternately, indicating the receiver does work but no signal received yet.
- 4.1.6 Turn on the microphone, one of DIVERSITY indicator in the receiver will light on with another off, indicating the signal received. If the Indicator A light on means the inner receiver A get signal while the B works if the B light on. Moving the microphone, the one of the DIVERSITY will selected to light on automatically according to the better signal.
- 4.1.7 Set the VOLUME to get proper volume without feedback.

### 4.2 Rack mounting a single 8010 receiver

4.2.1 Place a clamping slide (3) on each rack ear (2), checking that the pegs on the clamping slide (3) engage in the fixing holes on the rack ears (2) as shown in fig. 22a and b.

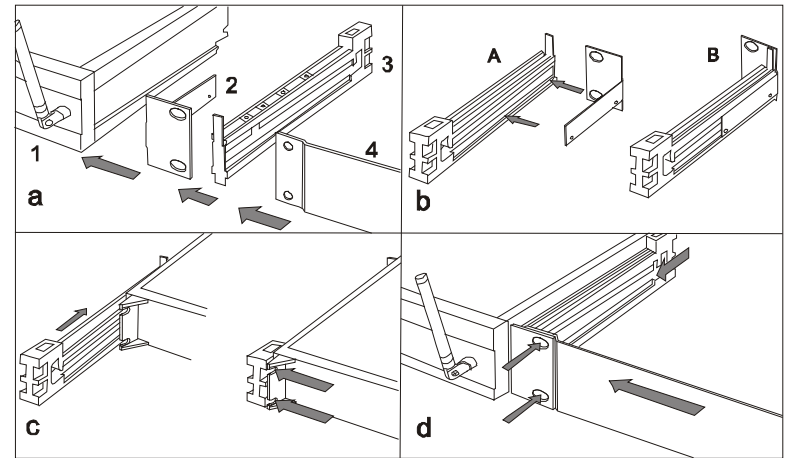

Fig.22 Rack mounting receiver 8010

- 4.2.2 Slide the clamping slide (3) and the rack ears (2) into the fixing rails on both sides of the receiver (1) from rear to front as shown in fig. 22d
- 4.2.3 Tighten the two supplied screws in the clamping slides (3) CW to fix the rack ears (2) on the receiver (1).
- 4.2.4 Use the supplied self-tapping screws to screw the clamping slides (3) to the side panels as shown in fig. 22c
- 4.2.5 Use the supplied machine bolts to fix the supplies blank panel (4) to the left or right rack ear (2) as shown in fig. 22d.
- 4.2.6 Use the supplies installation bolts to install the receiver (1) in the 19" rack.

### 4.3 Mounting two 8010 receiver side by side

- 4.3.1 Fix the rack ear and clamping slide to the outside panel of each receiver referring to steps 4.2.1 through 4.2.3 above.
- 4.3.2 Insert a clamping slide (3) with no rack ear (2) into the fixing rails on the inside panel of one receiver (1).
- 4.3.3 Insert the receiver (1) with the clamping slide (3) on its inside panel into the fixing rails on the inside panel of the other receiver (1).
- 4.3.4 Tighten the two supplied screws in the inside clamping slide (3) CW to connect the two receivers (1).
- 4.3.5 Use the supplied self-tapping screws to screw the clamping slides (3) to the receivers (1) tightly.

4.3.6 Use the supplied installation bolts to install the receivers (1) in the 19" rack.

#### 4.4 Receiver 8220

4.4.1 Receiver 8220 was shown in Fig.23. Take out the receiver and the receive antennas from packing box; place the receiver near the performance area (stage), mounting the antennas to the receiver. Point the antennas upward. Make sure, that the transmitter (microphone) will never get any closer to the receiver than 10 ft (3m), optimum separation is 16 ft (5m). There should always be a direct line of sight between the microphone and receiver. Place the receiver least 5 ft (1.5m) away from any big metal objects, walls, scaffolding, ceilings, etc.

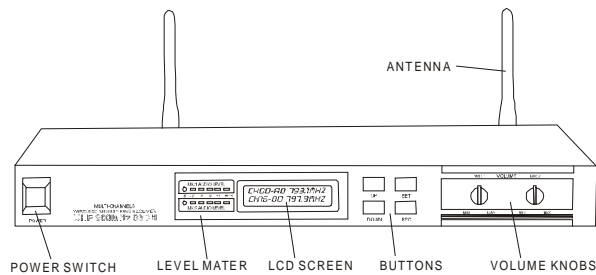

Fig.23 Receiver 8220

4.4.2 Connect MAXED OUTPUT in receiver and MIC INPUT in the amplifier with the supplied unbalanced audio cable. The Balanced socket (BALANCED) specializes in connecting sound stage with the optional balanced audio cable. Do not use the Balanced and Unbalanced Sockets simultaneously! This may cause signal loss or increased noise.

4.4.3 Check if the AC voltage stated on the rear panel of the receiver matches the AC electric socket in the wall before connecting the power cable in Receiver. Otherwise may cause irreparable damage to the unit.

4.4.4 Adjust the volume of the receiver and amplifier to "MIN" and turn on the receiver, the LCD screen of the receiver will light on and display as following:



The channel and frequency of the microphone 1 was shown in the first line, and the microphone 2 was shown in the second line. "CH00" or "CH16" is the decimal channel number, "A0" or "B0" is the hexadecimal channel number, "803.9MHz" or "808.7MHz" is the receive frequency. To change the channel, please press the "SET" key first to entry the setup status, then the LCD screen will display as following:



The rectangular block indicates that the channel of microphone 1 can be adjusted by pressing the "UP" key or "DOWN" key. If you press the "SET" key again, the rectangular block will move to the second line as below:



Now you can change the channel of the microphone 2. Press the "ESC" key to exit the adjustment status and the rectangular block will disappear.

4.4.5 Adjust the microphone and the receiver to the same channel, then turn on the microphone, the "RF" indicator of the receiver will light on, which means the receiver always receives the signal of the microphone. When you speak to the microphone, the LED level meter will denoting the magnitude of the sound.

4.4.6 Set the VOLUME to get proper volume without feedback.

#### 4.5 Receiver 8221

4.5.1 Receiver 8220 was shown in Fig.24. Take out the receiver and the receive antennas from packing box; place the receiver near the performance area (stage), mounting the antennas to the receiver. Point the antennas upward. Make sure, that the transmitter (microphone) will never get any closer to the receiver than 10 ft (3m), optimum separation is 16 ft (5m). There should always be a direct line of sight between the microphone and receiver. Place the receiver least 5 ft (1.5m) away from any big metal objects, walls, scaffolding, ceilings, etc.

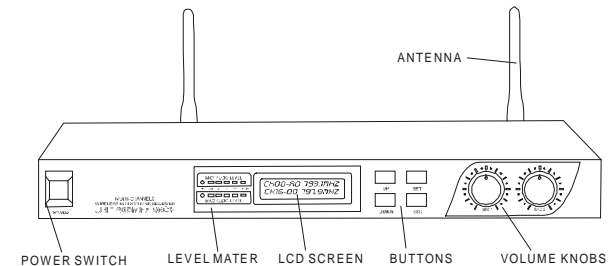

Fig.24 Receiver 8221

4.5.2 Connect MAXED OUTPUT in receiver and MIC INPUT in the amplifier with the supplied unbalanced audio cable. The Balanced socket (BALANCED) specializes in connecting sound stage with the

optional balanced audio cable. Do not use the Balanced and Unbalanced Sockets simultaneously! This may cause signal loss or increased noise.

4.5.3 Check if the AC voltage stated on the rear panel of the receiver matches the AC electric socket in the wall before connecting the power cable in Receiver. Otherwise may cause irreparable damage to the unit.

4.5.4 Adjust the volume of the receiver and amplifier to "MIN" and turn on the receiver, the LCD screen of the receiver will light on and display as following:



The channel and frequency of the microphone 1 was shown in the first line, and the microphone 2 was shown in the second line. "CH00" or "CH16" is the decimal channel number, "A0" or "B0" is the hexadecimal channel number, "803.9MHz" or "808.7MHz" is the receive frequency. To change the channel, please press the "SET" key first to entry the setup status, then the LCD screen will display as following:



The rectangular block indicates that the channel of microphone 1 can be adjusted by pressing the "UP" key or "DOWN" key. If you press the "SET" key again, the rectangular block will move to the second line as below:



Now you can change the channel of the microphone 2. Press the "ESC" key to exit the adjustment status and the rectangular block will disappear.

4.5.5 Adjust the microphone and the receiver to the same channel, then turn on the microphone, the "RF" indicator of the receiver will light on, which means the receiver always receives the signal of the microphone. When you speak to the microphone, the LED level mater will denoting the magnitude of the sound.

4.5.6 Set the VOLUME to get proper volume without feedback.

#### 4.6 Diversity receiver 8222

4.6.1 Receiver 8220 was shown in Fig.25. Take out the receiver and the receive antennas from packing box; place the receiver near the performance area (stage), mounting the antennas to the receiver. Point the antennas upward. Make sure, that the transmitter (microphone) will never get any closer to the receiver than 10 ft (3m), optimum separation is 16 ft (5m). There should always be a direct line of

sight between the microphone and receiver. Place the receiver least 5 ft (1.5m) away from any big metal objects, walls, scaffolding, ceilings, etc.

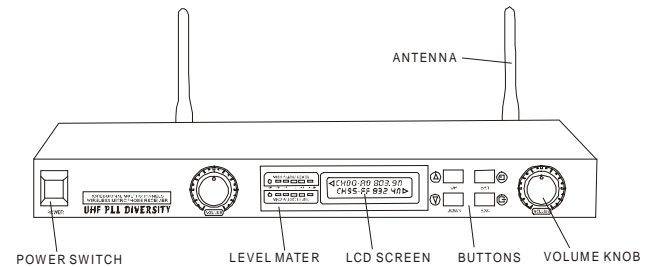
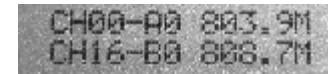

Fig.25 Receiver 8222

4.6.2 Connect MAXED OUTPUT in receiver and MIC INPUT in the amplifier with the supplied unbalanced audio cable. The Balanced socket (BALANCED) specializes in connecting sound stage with the optional balanced audio cable. Do not use the Balanced and Unbalanced Sockets simultaneously! This may cause signal loss or increased noise.

4.6.3 Check if the AC voltage stated on the rear panel of the receiver matches the AC electric socket in the wall before connecting the power cable in Receiver. Otherwise may cause irreparable damage to the unit.

4.6.4 Adjust the volume of the receiver and amplifier to "MIN" and turn on the receiver, the LCD screen of the receiver will light on and display as following:



The channel and frequency of the microphone 1 was shown in the first line, and the microphone 2 was shown in the second line. "CH00" or "CH16" is the decimal channel number, "A0" or "B0" is the hexadecimal channel number, "803.9MHz" or "808.7MHz" is the receive frequency. To change the channel, please press the "SET" key first to entry the setup status, then the LCD screen will display as following:

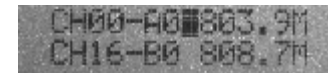

The rectangular block indicates that the channel of microphone 1 can be adjusted by pressing the "UP" key or "DOWN" key. If you press the "SET" key again, the rectangular block will move to the second line as below:

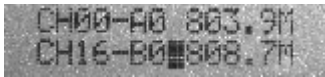

Now you can change the channel of the microphone 2. Press the "ESC" key to exit the adjustment status and the rectangular block will disappear.

- 4.6.5 Adjust the microphone and the receiver to the same channel, then turn on the microphone, the "RF" indicator of the receiver will light on, When you speak to the microphone, the LED level meter denoting the magnitude of the sound, which means the receiver always receives the signal of the microphone. In the same time, the LCD screen will display as following:

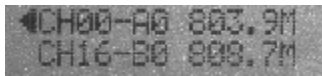

The arrow at left means the left antenna was using now. Possibly the LCD screen may display as following:

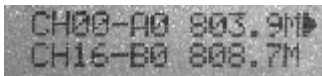

The arrow at right means right antenna was using now. If you move the microphone, the arrow will appear uncertain at left or right. This means the diversity circuit is working to eliminating the blind area.

- 4.6.6 Set the VOLUME to get proper volume without feedback.

## 4.7 Receiver 8223

- 4.7.1 Receiver 8223 was shown in Fig.26.

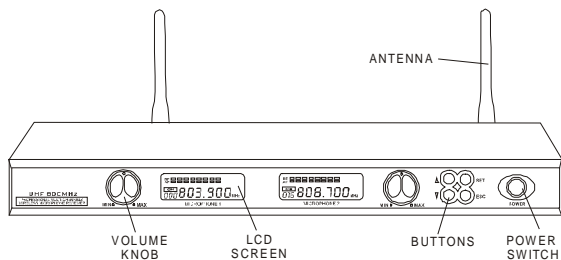

Fig.26 Receiver 8223

Take out the receiver and the receive antennas from packing box; place the receiver near the performance area (stage), mounting the antennas to the receiver. Point the antennas upward. Make sure, that the transmitter (microphone) will never get any closer to the receiver than 10 ft (3m),

optimum separation is 16 ft (5m). There should always be a direct line of sight between the microphone and receiver. Place the receiver least 5 ft (1.5m) away from any big metal objects, walls, scaffolding, ceilings, etc.

- 4.7.2 Connect MAXED OUTPUT in receiver and MIC INPUT in the amplifier with the supplied unbalanced audio cable. The Balanced socket (BALANCED) specializes in connecting sound stage with the optional balanced audio cable. Do not use the Balanced and Unbalanced Sockets simultaneously! This may cause signal loss or increased noise.
- 4.7.3 Check if the AC voltage stated on the rear panel of the receiver matches the AC electric socket in the wall before connecting the power cable in Receiver. Otherwise may cause irreparable damage to the unit.
- 4.7.4 Adjust the volume of the receiver and amplifier to "MIN" and turn on the receiver, the LCD screen of the receiver will light on and display as Fig.27:

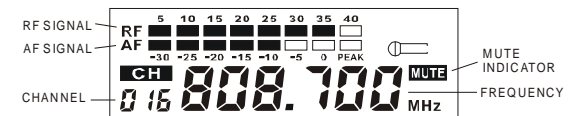

Fig.27 Screen of receiver 8223

Adjust the channel of the microphone as same as the receiver, then turn on the microphone, the "MUTE" will disappear, and the RF signal will be displayed. When you speak to the microphone, the AF signal will be displayed.

- 4.7.5 To change receive frequency (channel), press the SET key first, the "CH" in the left LCD screen (microphone 1) will flash, you can change the receive frequency of microphone 1 by press UP key or Down key. Press the SET key again, the "CH" in the right LCD screen (microphone 2) will flash, you can change the receive frequency of microphone 2 similarly. At any time, you can make sure your change and exit adjust state by press the ESC key.
- 4.7.6 Set the VOLUME to get proper volume without feedback.

## 4.8 True diversity receiver 8240

- 4.8.1 True diversity receiver 8240 was shown in Fig.28. Take out the receiver and the receive antennas from packing box; place the receiver near the performance area (stage), mounting the antennas to the receiver. Point the antennas upward. Make sure, that the transmitter (microphone) will never get any closer to the receiver than 10 ft (3m), optimum separation is 16 ft (5m). There should always be a direct line of sight between the microphone and receiver. Place the receiver least 5 ft (1.5m) away from any big metal objects, walls, scaffolding, ceilings, etc.

- 4.8.2 Connect MAXED OUTPUT in receiver and MIC INPUT in the amplifier with the supplied unbalanced audio cable. The Balanced socket (BALANCED) specializes in connecting sound stage with the

optional balanced audio cable. Do not use the Balanced and Unbalanced Sockets simultaneously!  
This may cause signal loss or increased noise.

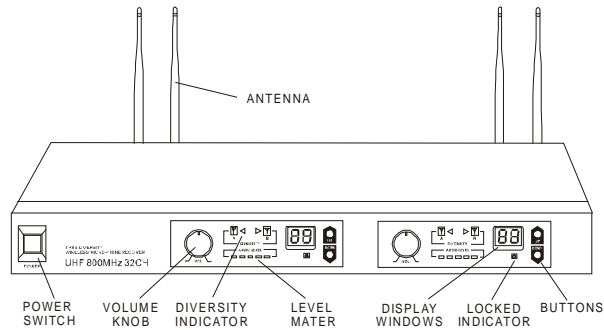

Fig.28 True diversity receiver 8240

4.8.3 Check if the AC voltage stated on the rear panel of the receiver matches the AC electric socket in the wall before connecting the power cable in Receiver. Otherwise may cause irreparable damage to the unit.

4.8.4 Adjust the volume of the receiver and amplifier to "MIN" and turn on the receiver, the LED screen of the receiver will light on and display some mutative characters, the last characters are the hexadecimal channel number. The first digital is the GROUP and the second digital is the CHANNEL. And the two Diversity indicators each side will flash alternately, indicating the receiver already working but no signal received yet.

4.8.5 Make sure the GROUP and the CHANNEL of the receiver are same to the microphones. The GROUP mark and CHANNEL listing of receiver 8240 in the rear panel, you can get the operation frequency of system from it.

4.8.6 Turn on a microphone, one of DIVERSITY indicator in the receiver will light on with another off, indicating the signal received. If the Indicator A light on means the inner receiver A get signal while the B works if the B light on. Moving the microphone, the one of the DIVERSITY will selected to light on automatically according to the better signal, This means the diversity circuit is working to eliminating the blind area. When you speak to the microphone, the LED level mater will denoting the magnitude of the sound.

4.8.7 Set the VOLUME to get proper volume without feedback.

4.8.8 The buttons of true diversity receiver 8240 could be locked. To lock the buttons, press the UP key and keep down before turn on the receiver, the LOCKED indictor will light on, and the buttons will be disabled. To unlock the buttons, turn off the receiver, press the UP key and keep down then turn on the receiver, the LOCKED indictor will gone out, and the buttons will be effective.

## 4.9 True diversity receiver 8242

4.9.1 True diversity receiver 8240 was shown in Fig.29. Take out the receiver and the receive antennas from packing box; place the receiver near the performance area (stage), mounting the antennas to the receiver. Point the antennas upward. Make sure, that the transmitter (microphone) will never get any closer to the receiver than 10 ft (3m), optimum separation is 16 ft (5m). There should always be a direct line of sight between the microphone and receiver. Place the receiver least 5 ft (1.5m) away from any big metal objects, walls, scaffolding, ceilings, etc.

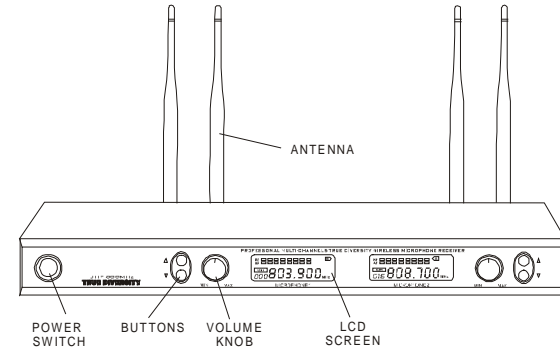

Fig.29 Receiver 8242

4.9.2 Connect MAXED OUTPUT in receiver and MIC INPUT in the amplifier with the supplied unbalanced audio cable. The Balanced socket (BALANCED) specializes in connecting sound stage with the optional balanced audio cable. Do not use the Balanced and Unbalanced Sockets simultaneously!  
This may cause signal loss or increased noise.

4.9.3 Check if the AC voltage stated on the rear panel of the receiver matches the AC electric socket in the wall before connecting the power cable in Receiver. Otherwise may cause irreparable damage to the unit.

4.9.4 Adjust the volume of the receiver and amplifier to "MIN" and turn on the receiver, the LCD screen of the receiver will light on and display as Fig.30:

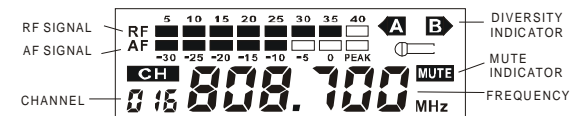

Fig.30 Screen of receiver 8242

4.9.5 Make sure the frequency or the channel of the receiver are same to the microphones. Turn on a microphone, the "MUTE" will disappear, and the RF signal will be displayed. When you speak to the microphone, the AF signal will be displayed. In the same time, one of the diversity indicator "A" or "B"

will be displayed, If the “A” appear means the inner receiver A get signal while the B works if the “B” appear. Moving the microphone, the one of the “A” and “B” will be selected to appear automatically according to the better signal, This means the diversity circuit is working to eliminating the blind area.

4.9.7 Set the VOLUME to get proper volume without feedback.

4.9.8 To change receive frequency, press the UP key (▲) or the DOWN key (▼), then the frequency and the channel will augment or abate synchronously.

4.9.9 The buttons of true diversity receiver 8242 could be locked. To lock the buttons, press the UP key and keep down before turn on the receiver, the “LoC oN” will appear on the LCD screen, and the buttons will be disabled, after this, if you press the buttons, the “LoC” will appear on the LCD screen, means the buttons was locked. To unlock the buttons, turn off the receiver, press the UP key and keep down then turn on the receiver, the “LoCoFF” will appear on the LCD screen, means the buttons was unlocked.

## 5 Specifications

### 5.1 Specifications of microphones

Model	T01	T04	T08	T10	T11	T12	T13	T14	
Freq Range	730~950MHz								
Freq number	16			96		16	96		
Freq stability	± 10ppm								
Modulation	FM								
RF output	10~50mW								
Audio bandwidth	40~20000Hz								
T.H.D. at 1kHz	≤0.5%								
Power supply	2×1.5V	1×6F22	2×1.5V						
Battery left	15 hours	5 hours	15 hours						

### 5.2 specifications of receivers

Model	8010	8220	8221	8222	8223	8240	8242
Freq Range	730~950MHz						
Freq number	16	96					
Oscillation mode	PLL synthesized						
Freq stability	± 10ppm						
Receive mode	Superheterodyne						
Diversity type	True	None		Intellectual	None	True	
Input sensitivity	-90dBm						
Audio bandwidth	40~20000Hz						
T.H.D. at 1kHz	≤0.5%						
S/N ratio	≥ 110dB						
Audio output	Balanced XLR and unbalanced 1/4" jack socket						
Power supply	110V 50Hz or 220V 60Hz						

Information in this manual is subject to change without notice and does not represent a commitment on the part of the vendor. We shall not be liable any loss or damage whatsoever arising from the use of information or any error contained in this manual.

No part of this manual may be reproduced, stored in a retrieval system or transmitted, in any form or by any means, electronic, electrical, mechanical, optical, chemical, including photocopying and recording, for any purpose without the express written permission of us.

It is recommended that all maintenance and service on the product should be carried out by us or our authorized agents. We cannot accept any liability whatsoever for any loss or damage caused by service, maintenance or repair by unauthorized personnel.